



SUMMA F SERIES ENHANCEMENTS 2020

To better align your Summa F Series products with your future projects and applications, Summa introduces several enhancements, including:

- New F1432 model in the F Series
- Improved Safety System
- ADC left now also standard included on all F Series models
- Updated GoProduce Software, including new functionalities
- Adjusted router & gantry system



INTRODUCING NEW SIZE: F SERIES F1432

The new flatbed size F1432 is bound to be a most efficient size for the processing of many popular applications.

- The F1432 offers a **wider working area**, enabling to process the popular 137 cm / 54" roll width.
- In addition, the **increased working length** provides sufficient margin to easily cut 3 m / 10 feet jobs.
- The F1432 is **shipped preassembled**, and packed into one single crate (4,5 m x 1,8 m - 1,8" x 0,7" which reduces the time needed for build-up and installation significantly. What's more, intervention from a Summa service technician is no longer needed for the installation, which can now easily be done by a certified Summa dealer (lower installation costs).
- The F1432 is equipped with **the enhanced Safety System** (see further).



Key Specifications

Specification	Metric	Imperial
Key Sizes		
Working Length	320 cm	126"
Working Width	142 cm	56"
Material Width	137 cm	54"
Dimensions		
Machine Width x Length	230 x 422 cm	90.7 x 166.1"
Shipping Dimensions (Main Crate - W x D x H)	435 x 22.5 x 178.5 cm	178.3 x 87.6 x 70.3"
Shipping Weight (Main Crate)	TBD	TBD

For all specifications, please contact your Summa reseller.

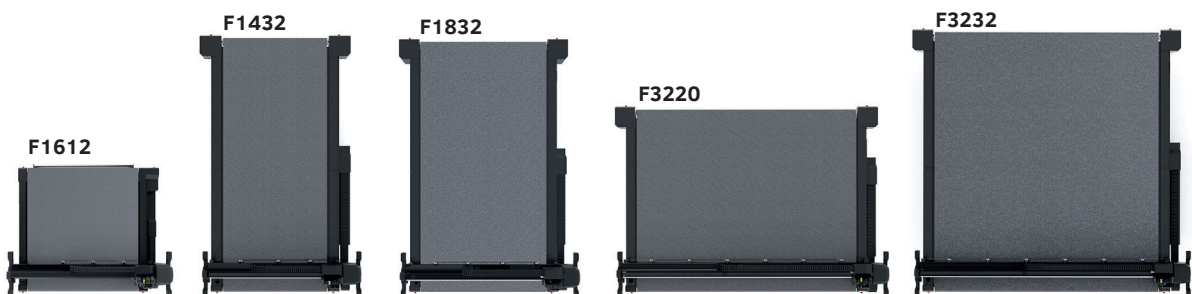



NEW ADVANCED SAFETY SYSTEM

The new advanced Safety system represents Summa's new standard, which ensures your F Series working area becomes even safer than before. The safety system ensures precise measurement of critical safety zones through **multiple integrated sensors**. It enables you to move around the flatbed more easily while your safety is being watched over.

Advantages of the Safety system:

- **Reduced footprint** of the F Series thanks to convenient placement of the Safety system on the top beam.
- **Better accessibility** because safety poles are no longer needed. This way, you can access parts of the work area while the machine is working in another area.
- Quick restart of the job after a safety break.
- The F Series now **complies with global health and safety requirements**.
- **Key certifications:**
 - CE: complying with the EU Machinery Directive, applicable in industrial production environments
 - NRTL: certification for North America (new, cCSAus pending)



Video available at:
www.summa.com/video/safety-system or scan the QR code

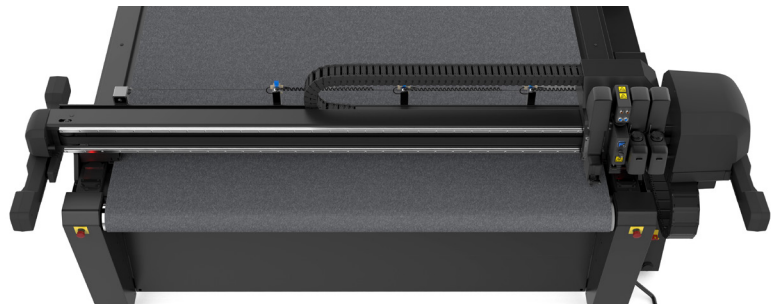
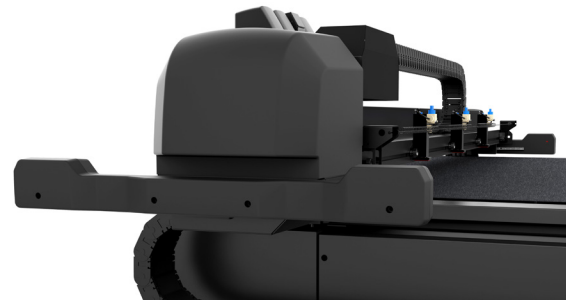

NOW A STANDARD FEATURE: ADC LEFT

Since the launch of the Automated Depth Control (ADC), the device has proven to be a most practical feature. The ADC right was already standard included on the F Series. To increase flexibility and automation in your workflow even more, also **the ADC left is now integrated as standard feature**.

Advantages of the ADC left:

- Possibility to also calibrate tools mounted in the first slot of the head automatically, ensuring a quick and reliable setup of all tools available.
- Easy tool adjustment that is compatible with the new Safety system.
- No remote controller needed.
- More automation means less operator errors, means increased yield.
- Unique feature that is only available on Summa F Series cutters.



F SERIES ENHANCEMENT: ROUTING SYSTEM & GANTRY

Among the F Series enhancements are a few additional adjustments that will be included. These enable easy access to the F Series flatbed table, protect electronics and enhance compatibility with the new Safety system.

- **The Routing system** has been adjusted for compatibility with the integrated Safety system.
- **The gantry** is prevented from blocking access to the electronic cabinet, making the unit easier to service.
- **The Routing system's electronics** are now mounted in an extra enclosure to protect them against dust.



NEW SOFTWARE RELEASE: GOPRODUCE 2.0

Along with the F Series enhancements related to hardware, it is the software that enables you to make good use of the machine's functionalities. This results in the release of the new GoProduce 2.0 software.

GoProduce 2.0 offers you various new functionalities, among which:

- **Twin X** enabling GoProduce to read cutting files prepared for the Summa roll cutters. This way, the Twin workflow, which was previously only available on OPOS CAM roll cutter units, can now be used on all Summa roll cutter types, equipped with an OPOS X sensor.
- **Back side cutting with edge detection** (worth to repeat in this list), reduces production time considerably.
- **Hot folder** for automatic processing of jobs that are placed in this folder, treated as a job queue.
- **Tool priority list**, where the software automatically selects the best tool available for the job.
- **The remote controller** will now be supported in GoProduce, enabling users to move the camera to the registration marks.

GoProduce 2.0 will be standard integrated with every new F Series installation. For existing F Series installations, an upgrade fee to GoProduce 2.0 is applicable. Please contact your Summa reseller for more information